

METAL PLUS LLC

TEST REPORT

SCOPE OF WORK

ANSI/ASSE Z359.18 (SECTIONS 4.2.1.1, 4.2.2.1 AND 4.2.3.1) TESTING
OF UNIVERSAL SAFETY ANCHOR

REPORT NUMBER

J5196.01-109-42

TEST DATES

03/25/19 - 03/27/19

ISSUE DATE

04/22/19

REVISED DATE

5/2/19

RECORD RETENTION END DATE

03/27/23

PAGES

19

DOCUMENT CONTROL NUMBER

GFT-OP-10c (AUGUST 27, 2018)

© 2017 INTERTEK

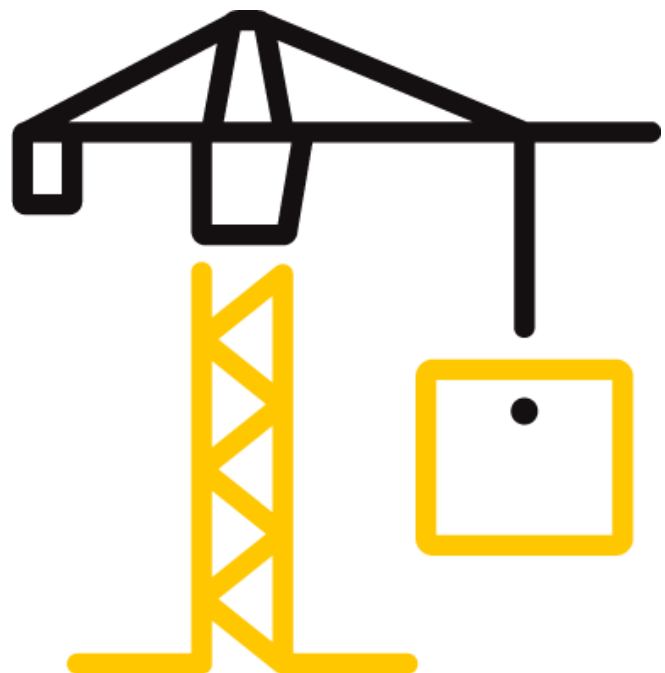

TEST REPORT FOR METAL PLUS LLC

Report No.: J5196.01-109-42

Revision 1: 05/02/19

Date: 04/22/19

REPORT ISSUED TO

METAL PLUS LLC

214 Wallens Hill Road

Winsted, CT 06098

SECTION 1

SCOPE

Intertek Building & Construction (B&C) was contracted by Metal Plus LLC to perform testing in accordance with ANSI/ASSE Z359.18 Sections 4.2.1.1, 4.2.2.1 and 4.2.3.1, on their Universal Safety Anchor. Results obtained are tested values and were secured by using the designated test method. Testing was conducted at Intertek B&C test facility in York, Pennsylvania.

This report does not constitute certification of this product nor an opinion or endorsement by this laboratory. Intertek B&C will service this report for the entire test record retention period. The test record retention period ends four years after the test date. Test records, such as detailed drawings, datasheets, representative samples of test specimens, or other pertinent project documentation, will be retained for the entire test record retention period.

For INTERTEK B&C:

COMPLETED BY:	Robert Spayd	REVIEWED BY:	Timothy J. McGill
TITLE:	Technician – Structural Systems Testing	TITLE:	Manager – Product Testing
SIGNATURE:		SIGNATURE:	
DATE:	05/02/19	DATE:	05/02/19

COMPLETED BY:	Robert J. Beatty
TITLE:	Technician – Product Testing
SIGNATURE:	
DATE:	05/02/19

RJB: wnl

This report is for the exclusive use of Intertek's Client and is provided pursuant to the agreement between Intertek and its Client. Intertek's responsibility and liability are limited to the terms and conditions of the agreement. Intertek assumes no liability to any party, other than to the Client in accordance with the agreement, for any loss, expense or damage occasioned by the use of this report. Only the Client is authorized to permit copying or distribution of this report and then only in its entirety. Any use of the Intertek name or one of its marks for the sale or advertisement of the tested material, product or service must first be approved in writing by Intertek. The observations and test results in this report are relevant only to the sample(s) tested. This report by itself does not imply that the material, product, or service is or has ever been under an Intertek certification program.

TEST REPORT FOR METAL PLUS LLC

Report No.: J5196.01-109-42

Revision 1: 05/02/19

Date: 04/22/19

SECTION 2

TEST METHOD

The specimens were evaluated in accordance with Sections 4.2.1.1, 4.2.2.1 and 4.2.3.1 of the following:

ANSI/ASSE Z359.18-2017, Safety Requirements for Anchorage Connectors for Active Fall Protection Systems

SECTION 3

MATERIAL SOURCE/INSTALLATION

Test samples were provided by the client. Representative samples of the test specimens will be retained by Intertek B&C for a minimum of four years from the test completion date.

Simulated Substrate Construction and Installation:

Specimens were individually mounted on either a 22 gauge (0.030") or a 24 gauge (0.020") thick steel standing seam roof deck. The standing seam roof was mounted to a simulated roof deck. The roof deck was constructed from 2x4 Southern Yellow Pine (SYP) and nominal 5/8" plywood sheathing. The sheathing was secured to the 2x4 lumber with #10 x 1" flat head screws spaced 1/2" from the ends of the deck and 3" on center along the short side and 1/2" from the ends of the deck and 3-1/2" on center along the long side. The wood roof deck was rigidly fastened to the concrete floor for the static strength test and clamped to a rigid steel test fixture for the dynamic strength and residual dynamic strength tests. The test specimen was secured to a seam on the steel deck. See Section 10 for photographs.

SECTION 4

TEST SPECIMEN DESCRIPTION

A two-piece hinged aluminum mechanism 2-1/2" wide by 3-1/2" tall by 8" long. Each piece is 5/8" thick and is held together with a 0.391" diameter hinge pin. The inside dimensions when closed are 1-1/4" wide by 2-1/2" tall. The safety ring is 304 stainless steel with an outside diameter of 2.104" and an inside diameter of 1.243". The anchor is secured with three 1/2-13 by 3-3/4" long square head bolts with an accompanying nut, lock washer, and washer. See Section 10 for photographs and Section 11 for drawings.

TEST REPORT FOR METAL PLUS LLC

Report No.: J5196.01-109-42

Revision 1: 05/02/19

Date: 04/22/19

SECTION 5 EQUIPMENT

ASSET NO.	DESCRIPTION	CALIBRATION DUE
63162	Mule	02/13/19
62414	Load Cell	01/24/19
INT00972	Stop Watch	02/12/19
005532	Load Cell	11/05/19
005531	Load Cell Reader	11/05/19
INT00680	Test Weight 282lbs	Calibrate only if damaged

SECTION 6 LIST OF OFFICIAL OBSERVERS

NAME	COMPANY
Mario Lallier	Metal Plus LLC
Ruth Lallier	Metal Plus LLC
Robert Spayd	Intertek B&C
Scott Gladfelter	Intertek B&C
Timothy J. McGill	Intertek B&C
Robert J. Beatty	Intertek B&C

SECTION 7 TEST PROCEDURE

Static Strength Test: Section 4.2.11

The specimens were individually installed onto the standing seam roof and each bolt was torqued to either 60 ft lbs or 80 ft lbs (specified in the results). A hydraulic cylinder with a load cell capable of reading 25,000 lbs was attached to the safety ring of the anchor. Each specimen was loaded to 5,000 lbs, perpendicular to the direction of the standing seam roof, and the load was held for three minutes. The load was then released and observations were noted.

See photographs in Section 10 and drawings in Section 11 for more information.

Dynamic Strength Test: Section 4.2.2.1

The specimens were installed onto the standing seam roof and each bolt was torqued to either 60 ft lbs or 80 ft lbs (specified in the results). The test deck was secured to the test fixture with the seams running vertically. The test weight and lanyard with a load cell were attached to the safety ring of the anchor. The test weight was adjusted to the drop height of 3' and released via quick release.

TEST REPORT FOR METAL PLUS LLC

Report No.: J5196.01-109-42

Revision 1: 05/02/19

Date: 04/22/19

Residual Dynamic Strength Test: Section 4.2.3.1

The specimens were installed onto the standing seam roof and each bolt was torqued to either 60 ft lbs or 80 ft lbs (specified in the results). The test deck was secured to the test fixture with the seams running vertically. The test weight and lanyard with a load cell were attached to the safety ring of the anchor. The test weight was adjusted to the drop height of 3' and released via quick release. After the initial drop the test weight was kept in place for 60 seconds.

TEST REPORT FOR METAL PLUS LLC

Report No.: J5196.01-109-42

Revision 1: 05/02/19

Date: 04/22/19

SECTION 8

TEST RESULTS

Specimen #1: Loading Parallel to Direction of Standing Seam Roof on 24 Gauge Steel Deck

TEST	MAXIMUM LOAD (lb)	SIMULATED SUBSTRATE	BOLT INSTALLATION TORQUE (ft-lbs)	OBSERVATIONS
Static Strength	3575	24 gauge	60	The specimen did not achieve specified load due to deformation of mechanical standing seam. Anchor undamaged.
Dynamic Strength	3284	24 gauge	60	The specimen slid 9" down the standing seam of the simulated substrate before coming to a complete stop.
Residual Strength	3142	24 gauge	60	The specimen slid 3-1/4" down the standing seam of the simulated substrate before coming to a complete stop. There was no additional movement during the 60 second hold time.

Specimen #2: Loading Parallel to Direction of Standing Seam Roof on 24 Gauge Steel Deck

TEST	MAXIMUM LOAD (lb)	SIMULATED SUBSTRATE	BOLT INSTALLATION TORQUE (ft-lbs)	OBSERVATIONS
Static Strength	4246	24 gauge	80	The specimen did not achieve specified load due to deformation/cracking of mechanical standing seam. Anchor undamaged.
Dynamic Strength	2715	24 gauge	80	The specimen slid 4-1/4" down the standing seam of the simulated substrate before coming to a complete stop.
Residual Strength	2675	24 gauge	80	The specimen slid 9" down the standing seam of the simulated substrate before coming to a complete stop. There was no additional movement during the 60 second hold time.

TEST REPORT FOR METAL PLUS LLC

Report No.: J5196.01-109-42

Revision 1: 05/02/19

Date: 04/22/19

Specimen #3: Loading Perpendicular to Direction of Standing Seam Roof on 24 Gauge Steel Deck

TEST	MAXIMUM LOAD (lb)	SIMULATED SUBSTRATE	BOLT INSTALLATION TORQUE (ft-lbs)	OBSERVATIONS
Static Strength	4675	24 gauge	60	The specimen did not achieve specified load due to deformation/cracking of mechanical standing seam. Anchor undamaged.
Dynamic Strength	5083	24 gauge	60	The seam of the simulated substrate panels opened up to create a 12" wide by 1/2" (at largest) gap.
Residual Strength	4526	24 gauge	60	The seam of the simulated substrate panels opened up to create a 16" wide by 1" (at largest) gap. There was no additional movement during the 60 second hold time.

Specimen #4: Loading Parallel to Direction of Standing Seam Roof on 22 Gauge Steel Deck

TEST	MAXIMUM LOAD (lb)	SIMULATED SUBSTRATE	BOLT INSTALLATION TORQUE (ft-lbs)	OBSERVATIONS
Static Strength*	5195	22 gauge	80	The specimen sustained 5000 lbs for three minutes without failure. Anchor undamaged.
Dynamic Strength	2429	22 gauge	80	The specimen slid 7-1/8" down the standing seam of the simulated substrate before coming to a complete stop.
Residual Strength	2469	22 gauge	80	The specimen slid 8" down the standing seam of the simulated substrate before coming to a complete stop. There was no additional movement during the 60 second hold time.

*Testing is compliant with OSHA 1910.140(C)(7) - Proof Testing/Ulimate Failure Load Evaluation and OSHA 1910.140(C)(8) - Static Strength Evaluation for one direction

TEST REPORT FOR METAL PLUS LLC

Report No.: J5196.01-109-42

Revision 1: 05/02/19

Date: 04/22/19

Specimen #5: Loading Parallel to Direction of Standing Seam Roof on 22 Gauge Steel Deck

TEST	MAXIMUM LOAD (lb)	SIMULATED SUBSTRATE	BOLT INSTALLATION TORQUE (ft-lbs)	OBSERVATIONS
Dynamic Strength	1919	22 gauge	60	The specimen slid 11-1/4" down the standing seam of the simulated substrate before coming to a complete stop.

Specimen #6: Loading Perpendicular to Direction of Standing Seam Roof on 22 Gauge Steel Deck

TEST	MAXIMUM LOAD (lb)	SIMULATED SUBSTRATE	BOLT INSTALLATION TORQUE (ft-lbs)	OBSERVATIONS
Static Strength*	5106	22 gauge	60	The specimen sustained 5000 lbs for three minutes without failure. Anchor undamaged.

*Testing is compliant with OSHA 1910.140(C)(7) - Proof Testing/Ultimate Failure Load Evaluation and OSHA 1910.140(C)(8) - Static Strength Evaluation for one direction

Specimen #7: Loading Perpendicular to Direction of Standing Seam Roof on 24 Gauge Steel Deck

TEST	MAXIMUM LOAD (lb)	SIMULATED SUBSTRATE	BOLT INSTALLATION TORQUE (ft-lbs)	OBSERVATIONS
Static Strength*	5183	24 gauge	80	The specimen sustained 5000 lbs for three minutes without failure. Anchor undamaged.

*Testing is compliant with OSHA 1910.140(C)(7) - Proof Testing/Ultimate Failure Load Evaluation and OSHA 1910.140(C)(8) - Static Strength Evaluation for one direction

TEST REPORT FOR METAL PLUS LLC

Report No.: J5196.01-109-42

Revision 1: 05/02/19

Date: 04/22/19

SECTION 9 PHOTOGRAPHS

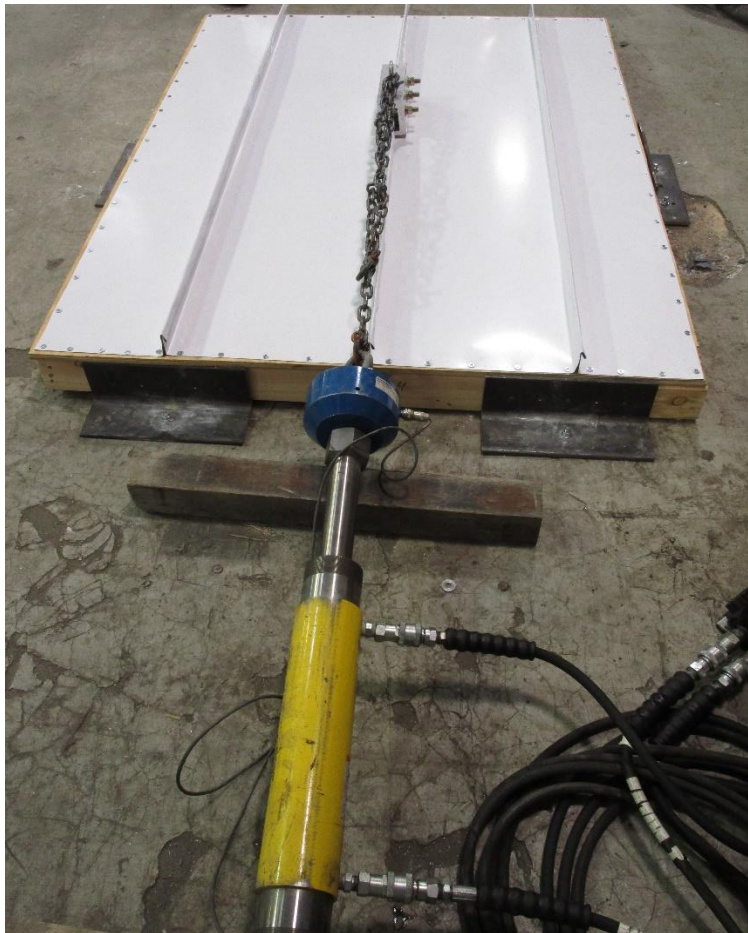

Photo No. 1
Static Strength Setup for Test Parrell to Direction of Standing Seam Roof

TEST REPORT FOR METAL PLUS LLC

Report No.: J5196.01-109-42

Revision 1: 05/02/19

Date: 04/22/19

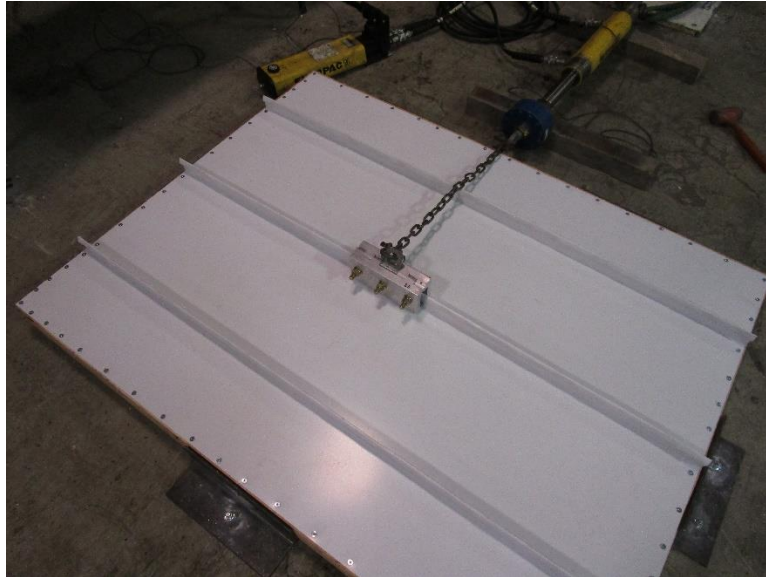

Photo No. 2

Static Strength Setup for Test Perpendicular to Direction of Standing Seam Roof



Photo No. 3

Specimen under Load during Test Perpendicular to Direction of Standing Seam Roof

TEST REPORT FOR METAL PLUS LLC

Report No.: J5196.01-109-42

Revision 1: 05/02/19

Date: 04/22/19

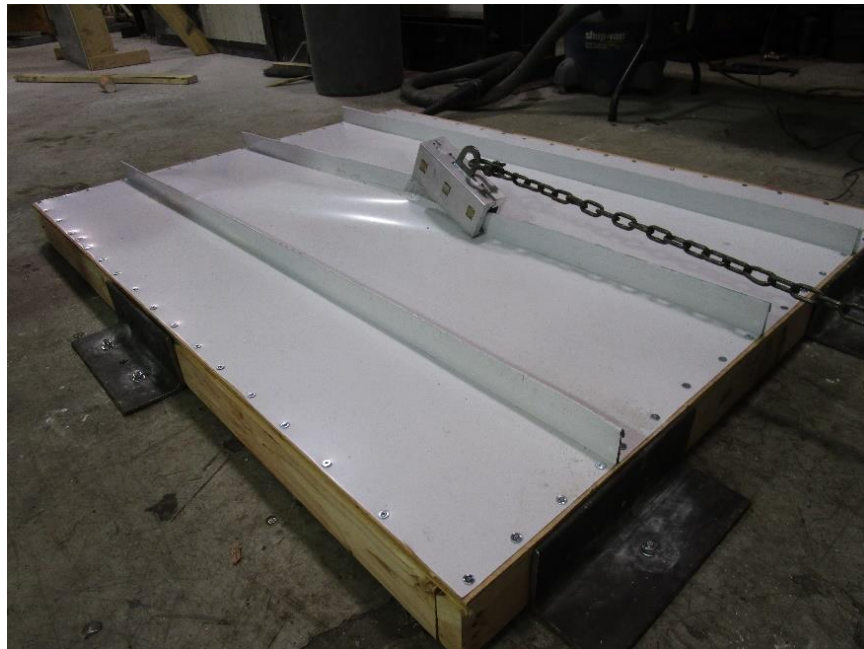

Photo No. 4

Specimen under Load during Test Parallel to Direction of Standing Seam

TEST REPORT FOR METAL PLUS LLC

Report No.: J5196.01-109-42

Revision 1: 05/02/19

Date: 04/22/19



Photo No. 5
Dynamic Strength and Residual Strength Setup for Test
Perpendicular to Direction of Standing Seam Roof



Total Quality. Assured.

130 Derry Court
York, Pennsylvania 17406

Telephone: 717-764-7700
Facsimile: 717-764-4129
www.intertek.com/building

TEST REPORT FOR METAL PLUS LLC

Report No.: J5196.01-109-42

Revision 1: 05/02/19

Date: 04/22/19

SECTION 10

DRAWINGS

The "As-Built" drawings for the Universal Safety Anchor, which follow, have been reviewed by Intertek B&C and are representative of the project reported herein. Project construction was verified by Intertek B&C per the drawings included in this report. Any deviations are documented herein or on the drawings.

12 11 10 9 8 7 6 5 4 3 2 1

H

H

G

G

F

F

E

E

D

D

C

C

B

B

A

A

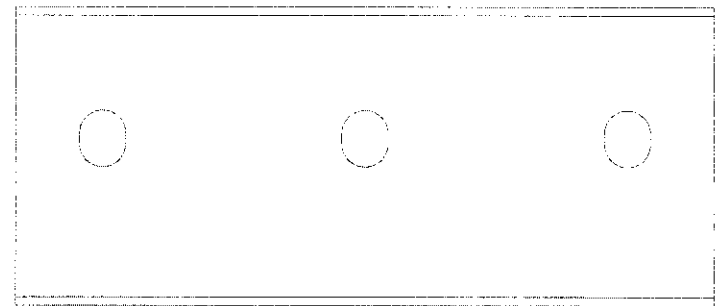
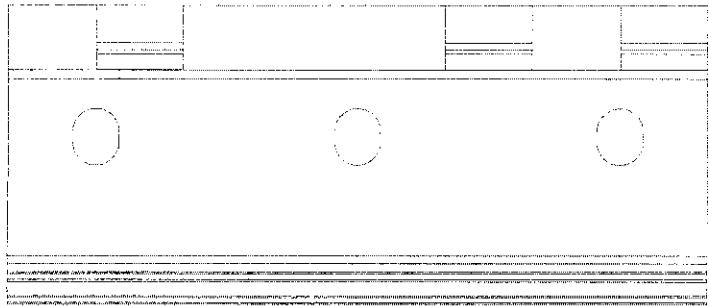
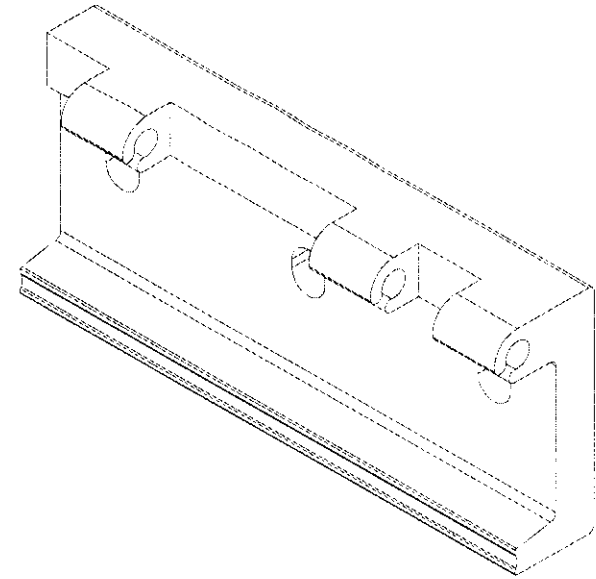
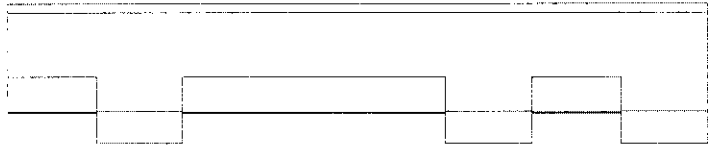

12 11 10 9 8 7 6 5 4 3 2 1

	Report #:	J5196
	Date:	4/5/19
	Verified by:	<i>[Signature]</i>

METAL PLUS
FALL PROTECTION
Extrusion 1 ^{A2}

12 11 10 9 8 7 6 5 4 3 2 1

H H

G G

F F

E E

D D

C C

B B

A A

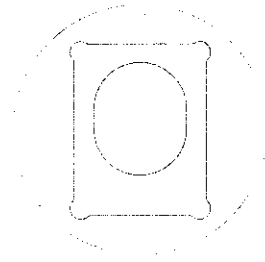
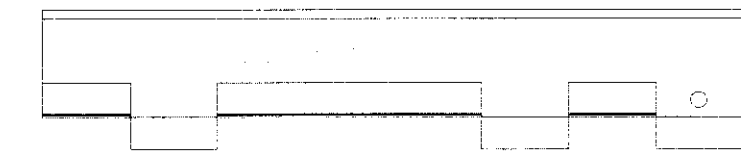

DETAIL A
SCALE 2:1

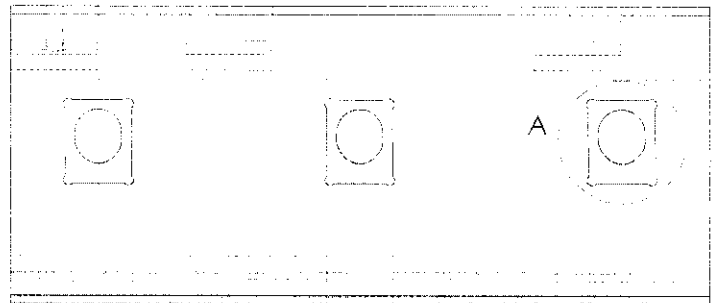
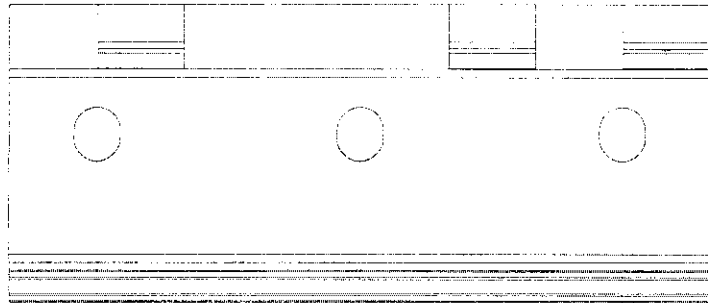
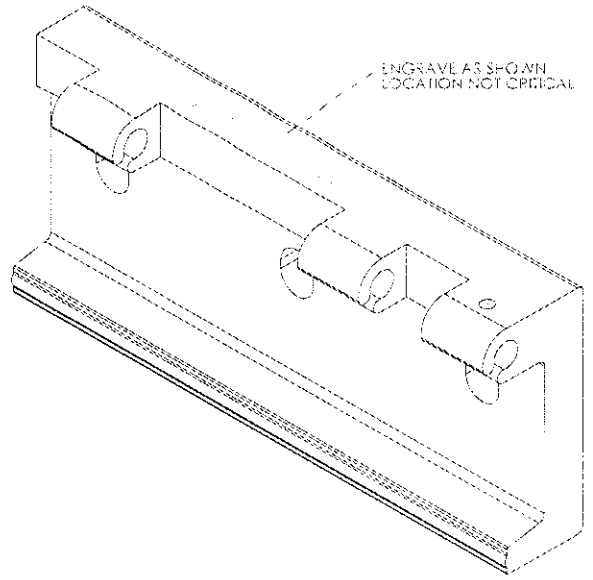

12 11 10 9 8 7 6 5 4 3 2 1

 Total Quality. Assured.	Report #:	J5196
	Date:	4/5/19
	Verified by:	<i>[Signature]</i>

METAL PLUS FALL PROTECTION
Extrusion 2 A2

SHEET	DWG. NO.	REV.	
A	Hinge Pin 1	1	
REV.	DESCRIPTION	DATE	APPROVED
1	DESIGN STAGE	11/5/2017	2/2/19

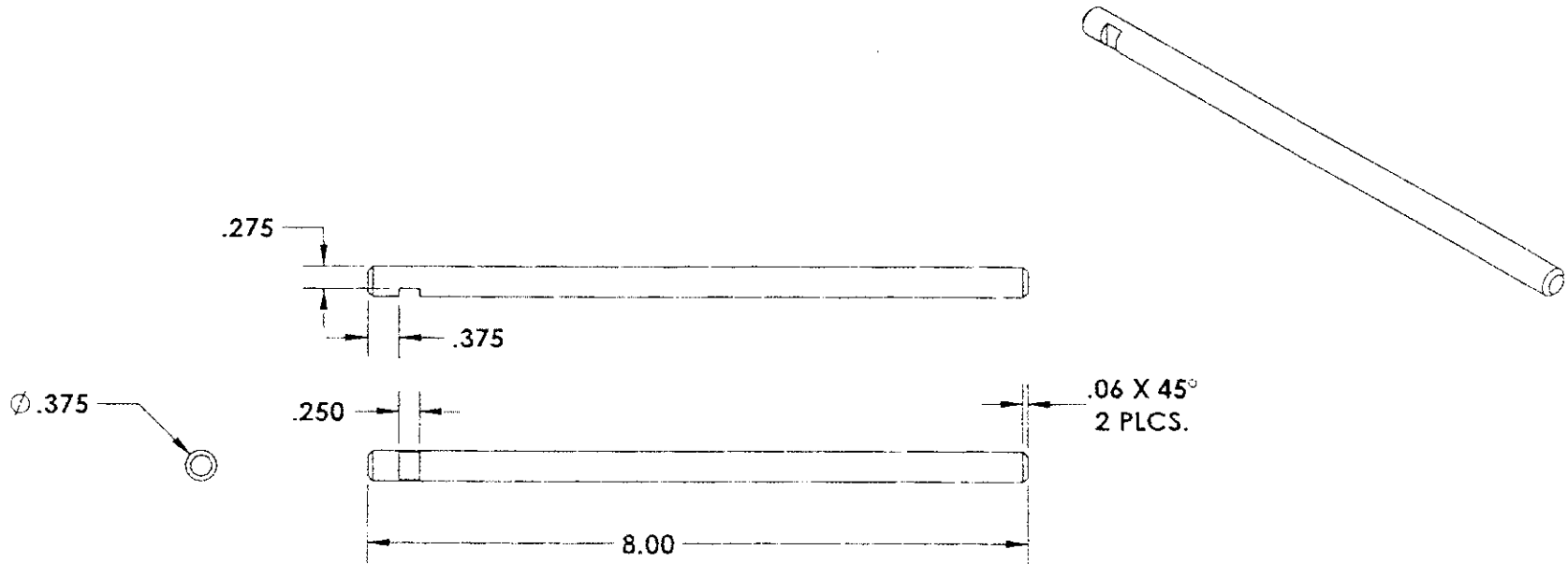

intertek Total Quality. Assured.	Report #:	J5196
	Date:	4/5/19
	Verified by:	<i>[Signature]</i>

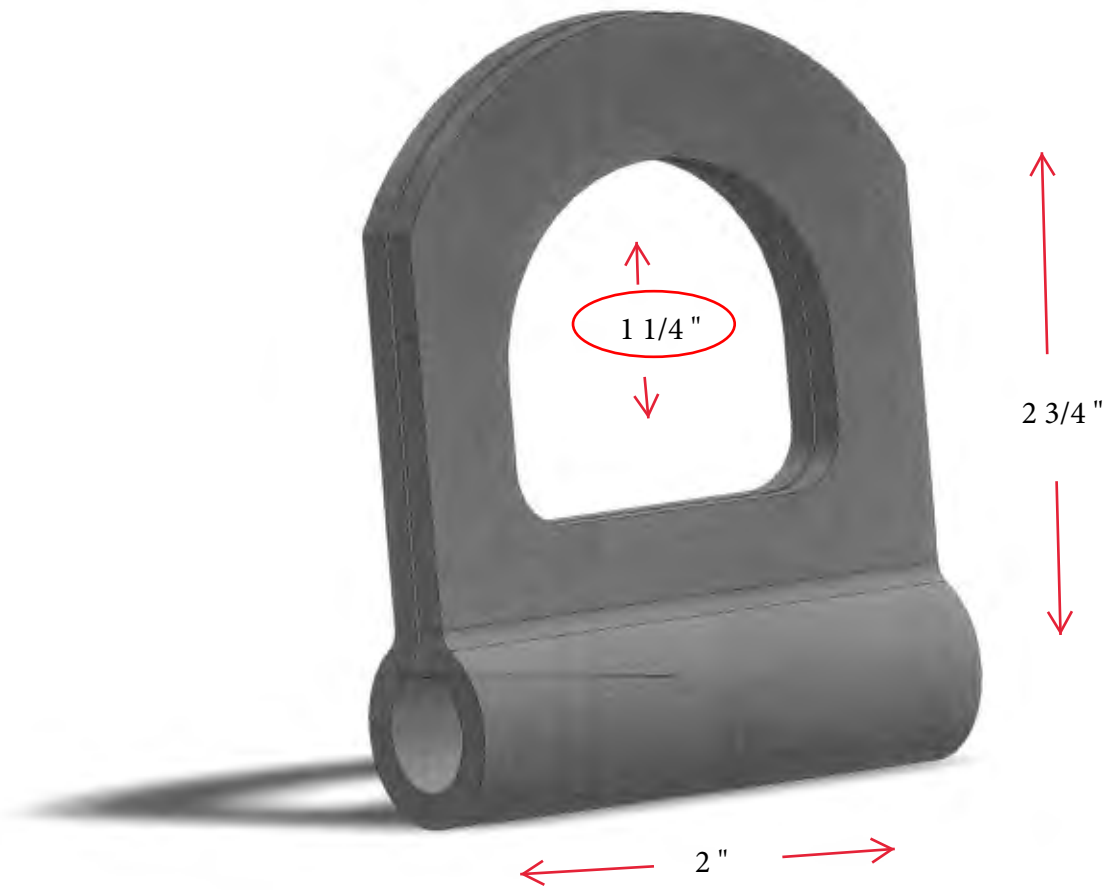

903881

$\varnothing .384 \pm .009$
R.100 TYP (4X)

1.625
1.250

R.375
FULL R TYP

REV.	DATE	ECN	APPV'D
A	01-08-19	RELEASED TO MFG	

.375
.750

28°

34°

3.500

.625

10°

.375 P.I.

(.030)

(.168)

R.165

1.225

1.255

intertek
Total Quality. Assured.

Report #: 151196
Date: 5/2/19
Verified by: [Signature]

NOTES:

- 1. UNLESS OTHERWISE SPECIFIED:
STANDARD ALUM. ASSOC. TOLERANCES APPLY
BREAK SHARP CORNERS R.025 MAX.
UNSPECIFIED RADII = .025

AREA: 2.983	CUSTOMER: METAL PLUS		
PERIM: 11.946	PART NAME: FALL PROTECTION MALE	DATE: 01-03-19	
OUTSIDE PERIMETER: 11.946		DWN BY: MRB	
WT./FT: 3.579	CUST DWG /REV: FALL PROTECTION MALE	SCALE: 1 : 1	
MAT'L 6061-T6	SECTION NO. 903881	CHK:	



Total Quality. Assured.

130 Derry Court
York, Pennsylvania 17406

Telephone: 717-764-7700
Facsimile: 717-764-4129
www.intertek.com/building

TEST REPORT FOR METAL PLUS LLC

Report No.: J5196.01-109-42

Revision 1: 05/02/19

Date: 04/22/19

SECTION 11

REVISION LOG

REVISION #	DATE	PAGES	REVISION
0	04/22/19	N/A	Original Report Issue
1	05/02/19	Section 10	Replaced drawing pages